

ELECTRIC STRIKES SI-3310

SPECIFICATIONS AND TECHNICAL DETAILS

Dimensions: 230mmLx37mmWx27mmD

Voltage: 12v DC

Modes: Fail secure/ Fail safe

Current: 400mA/12v

200mA/12v (F)

Face plate: Aluminum

Built-in voltage spike suppressor



■ INSTALLATION

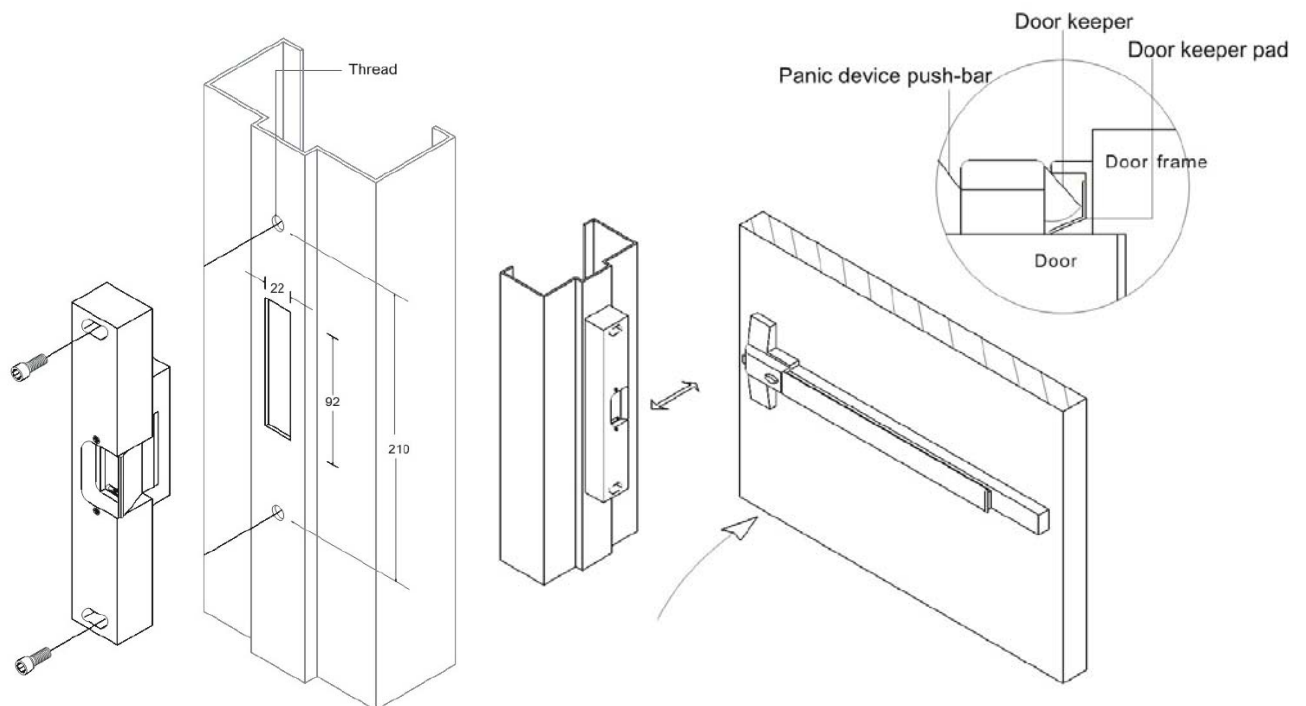

SPRINT RESERVES THE RIGHT TO CHANGE SPECIFICATIONS WITHOUT NOTICE.